

# HSF

**NOTES:**

Current Rating:5.0A AMP  
 Contact Resistance:10milliohm Max  
 Withstand Voltage:1000V AC/Minute  
 Insulation Resistance:1000Megohm Min  
 Operation Temperature:-25°C to +85°C

Housing Material:LCP+30%GF(UL94V-0)  
 Contact Material:Copper alloy  
 Contact plating:Au/Sn over Ni Plating

## Ordering Information

**WF3001-1 WR XX B X 1**

Terminal shape:  
WR:Wafer 90° DIP

NO.of Pins  
02~12Pin

Packing:  
0=PE Bag  
T=Tube  
A=Tray  
R=Tape&Reel

RECOMMENDED PCB LAYOUT  
 TOLERANCE IS ±0.05

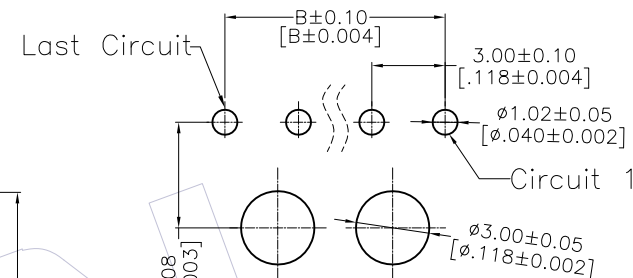
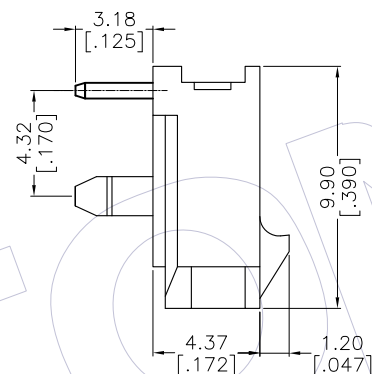
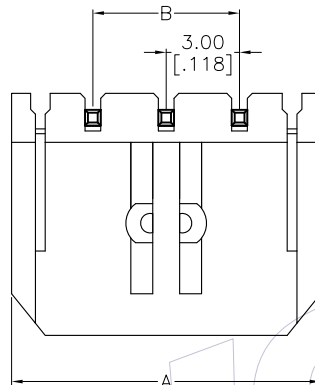

4-12 Circuit PCB LAYOUT

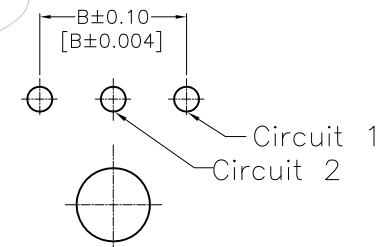

2-3 Circuit PCB LAYOUT

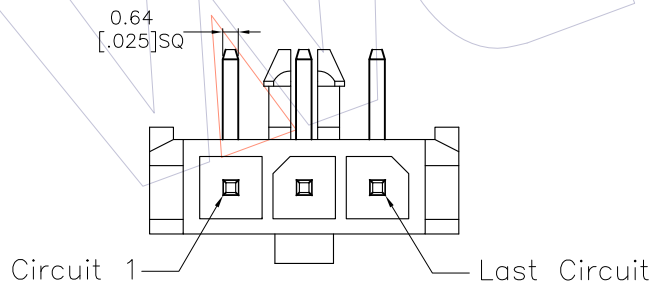

Circuit	A	B	C
02	9.65[0.380]	3.00[0.118]	NA
03	12.65[0.498]	6.00[0.236]	NA
04	15.65[0.616]	9.00[0.355]	4.70[0.185]
05	18.65[0.735]	12.00[0.473]	7.70[0.303]
06	21.65[0.853]	15.00[0.591]	10.70[0.421]
07	24.65[0.971]	18.00[0.709]	13.70[0.539]
08	27.65[1.089]	21.00[0.827]	16.70[0.657]
09	30.65[1.207]	24.00[0.945]	19.70[0.776]
10	33.65[1.325]	27.00[1.063]	22.70[0.894]
11	36.65[1.443]	30.00[1.181]	25.70[1.012]
12	39.65[1.561]	33.00[1.299]	28.70[1.130]

				OPERATION		DRAW		DATE		SCALE		PART NO.	
				X.X	±0.40	FZY		2012.05.02		1:1		△ WF3001-1WRXXBX1	
				X.XX	±0.25	CHECK		DATE		UNIT		TITLE:	
				X.XXX	±0.15	APPROVE		DATE		mm		3.0 Wafer Single Row	
				Angle	± 3'					inch		90° DIP With Post	
				DIM	TOL					SIZE		Customer NO.	
										A4			
										SHEET			
										1/1			
										PROJ.			
										☉			
A1	2012.05.03	料号由WF3001-1WRHXXBX1变更为WF3001-1WRXXBX1	Atomy										
A0	2011.12.20	NEW	-										
REV	DATE	MODIFICATION DESCRIPTION	CHANGE										

**WCON**  
 Http: www.wcon.com

WCON-Dongguan Tel: +86 769 85358920  
 WCON-Kunshan Tel: +86 512 57468408  
 Fax: +86 769 85358915  
 Fax: +86 512 57468468  
 E-mail: sales@wcon.com  
 E-mail: sales@wcon.com